

Ultra High-Speed Weld Hole Detection System

High-speed processing of continuous strip coils in the primary metals industry requires ultra high-speed detection of weld marker holes. Weld marker holes are used to mark the junction of coils welded together to form a continuous strip. It is imperative that no material from the welded zone be supplied to the customer.

However, since the welds are ground smooth and plated (or coated) over, they often become invisible. For this reason, most manufacturers will punch marker holes at the weld location. A hole detector is then used to locate the marker weld hole.

Over the years, photo-electric sensors have been used to detect these marker holes. The difficulty with these simple detectors is their lack of reliability. If a strip moves slightly off-center, the marker hole may pass unnoticed. Current incandescent and fluorescent based light sources may burn out.

Many older detectors are not fast enough for modern high-speed operations. The faster lines operate, the more difficult hole detection becomes. More elaborate and expensive systems have evolved that employ multiple detectors. Some systems employ high speed television cameras. Many of these systems have proven to be slow, unreliable and expensive.

The SCAN-A-LINE™ High-Speed Hole Detection System – HS System overcomes the typical problems associated with classic hole detection systems. The HS System consists of the Hole Detector Processing Unit – Model HDPU and the unique SCAN-A-LINE™ Model 10XAHS sensor.

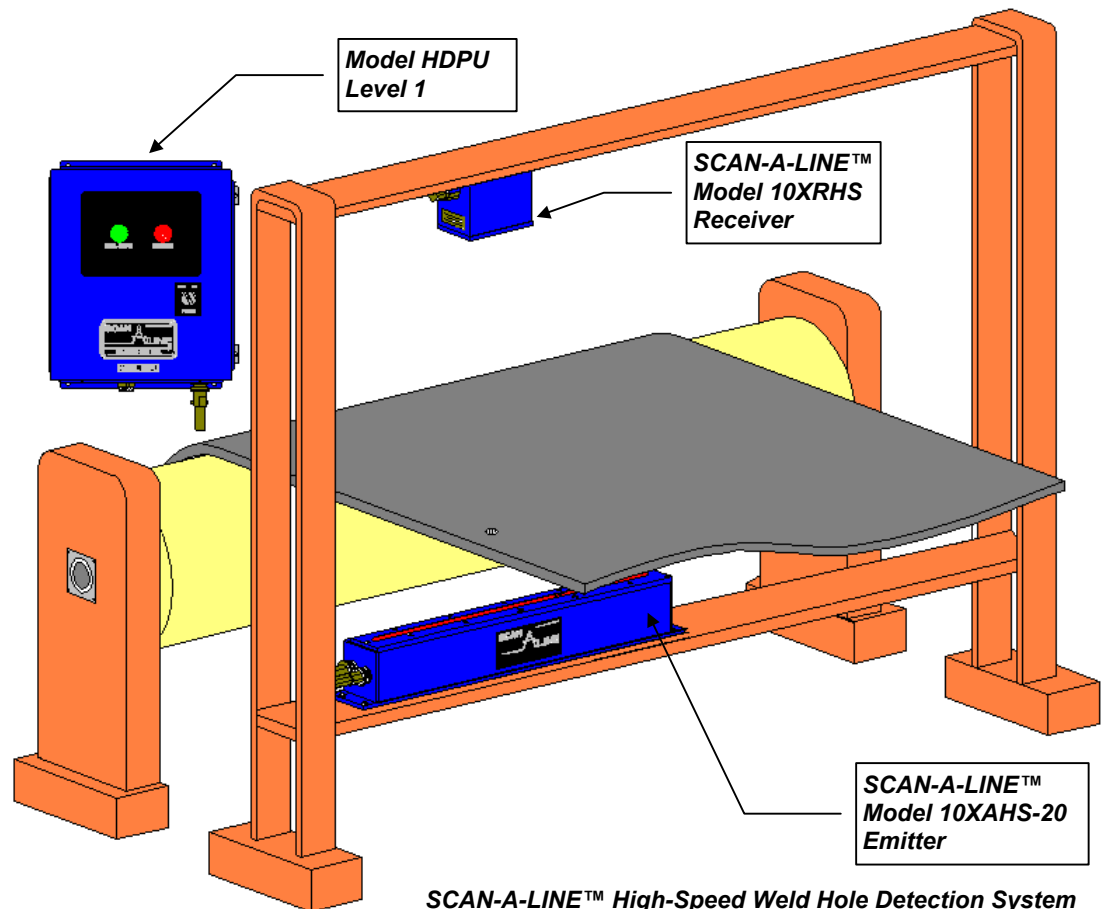

SCAN-A-LINE™ High-Speed Weld Hole Detection System

- Detection of 0.25" [6.3mm] Holes at Line Speeds up to 10,000 feet per minute [3048mpm]
- SCAN-A-LINE™ Solid State Reliability
- NO MOVING PARTS
- Simplicity of Installation
- Low Maintenance
- Dust, Mist and Vibration Tolerant
- Less Sensitive to Ambient Light than Previous Hole Detection Systems
- No Light Sources to Replace

SCAN-A-LINE™ High-Speed Weld Hole Detection System Components:

- ✓ 10XHS-Series Single- or Dual-Sensor System.
- ✓ Hole Detection Processing Unit – Model HDPU.
- ✓ Up to 50 linear feet [6.1m] of cabling.

The Ultra High-Speed Weld Hole Detection System – HS System provides customer ready relay contact closures and indicator lamps in the Model HDPU to indicate weld hole detection. The time that the indicator lamp remains lit and the relay contact stays closed is customer adjustable from 0.05 seconds to 10.00 seconds. A fail-safe circuit monitors the sensor power circuits and scan rate. An indicator lamp and relay contact closure signal normal system operation. This prevents missed holes due to cut cables, damaged sensors or other system malfunctions.

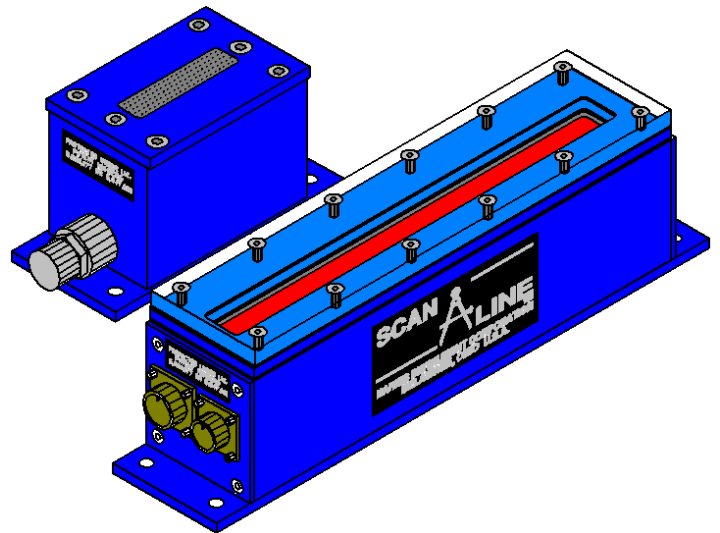

10XHS-Series Sensor – Model 10XAHS-10

Hole Detection Processing Unit – Model HDPU:

- ✓ Reports the detection of any light passing from the emitter to the receiver.



Model HDPU Level 1

SCAN-A-LINE™ High-Speed Hole Detection – 10XHS-Series Sensor Features:

- Unique SCAN-A-LINE™ Light Emitting Diode (LED) scanning technology provides the reliability of a 275-year mean-time-between-failure (MTBF) light source.
- High-frequency (200kHz) pulsed light source facilitates rejection of ambient light by the detector circuitry.
- Emitters are available in 10" [254mm] increments from 10" to 40" [254mm to 1016mm].
- Sensor scan time is 100µs regardless of emitter length.
- Optional *ULTRA-TOUGH™* enclosures for sensors – the ultimate in crash protection.
- SCAN-A-LINE™ Model 10XHS-Series sensors require minimum maintenance because they contain NO MOVING PARTS.

HARRIS INSTRUMENT CORPORATION

VAR Distributor

Welded Tube Pros LLC

Voice: (330) 658-7070 FAX (216) 937-0333

Email: budg@bright.net

www.weldedtubepros.com